

Mail: P.O. Box AA631
Evanston, IL 60204 USA



Phone: 847-864-8060
Toll Free: 866-379-1450

Ship: 1728 Brummel St.
Evanston, IL 60202 USA

THE JOHN HARDY COMPANY

Fax: 847-864-8076

www.johnhardyco.com

MPC-3000 Mic Preamp Card

January 1, 2004

Superior plug-in replacement for Sony MXP3000-series console mic preamps.

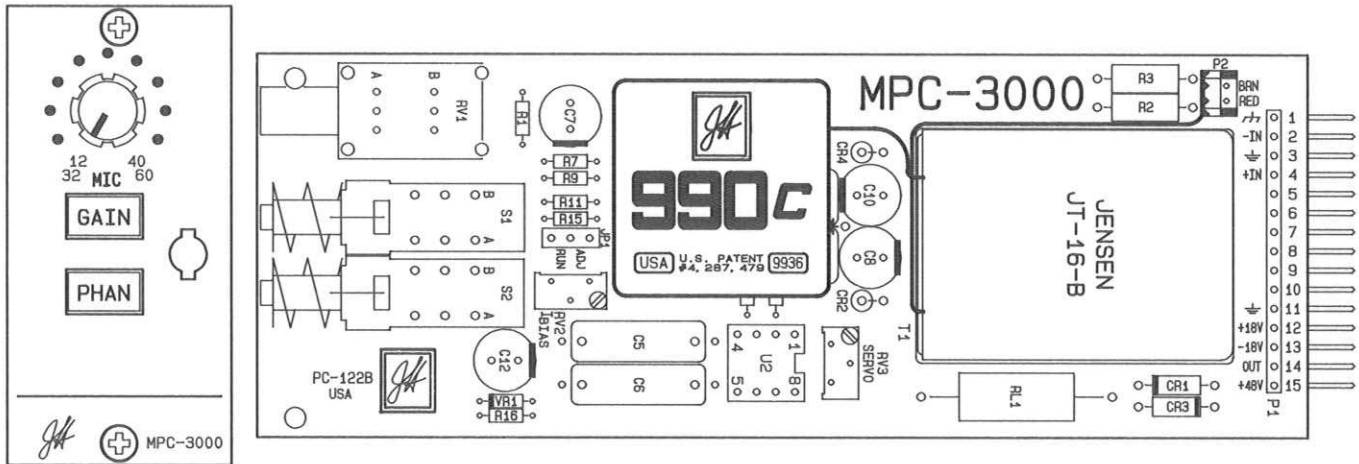

The MPC-3000 mic preamp card dramatically improves the performance of Sony MXP 3000-series consoles. The combination of the Jensen JT-16-B mic-input transformer (Jensen's best mic-input model), the 990C discrete class-A op-amp, and the total absence of coupling capacitors in the signal path results in superior audio performance. Just plug it in!

Highlights

The Jensen JT-16-B Input Transformer. This is Jensen's best mic-input model. Jensen is known worldwide for their superior audio transformers. If you thought transformers were a compromise, you haven't heard the JT-16-B!

The JT-16-B is a large, low impedance ratio (150:600 Ω) transformer made with a proprietary 80% nickel (nickel-iron-molybdenum) core material. The large size allows it to handle extremely high signal levels: +12dBu at 30Hz and above, +8dBu at 20Hz. The low ratio provides less distortion, flatter frequency response and more linear phase response than more typical high-ratio transformers (150:15k Ω). The proprietary 80% nickel core material is far superior to, and much more expensive than the steel often found in other transformers.

The JT-16-B outperforms transformerless mic preamps because it eliminates the input coupling capacitors that are required with transformerless designs. Capacitors degrade the audio signal because they have a property known as dielectric absorption, where some of the signal passing through the ca-

pacitor is absorbed by the dielectric of the capacitor, then released a short time later. This smears the signal. Transformerless designs require these capacitors to keep the phantom supply voltage from reaching the circuitry of the preamp. Transformers inherently block DC voltages, eliminating the need for the capacitors.

The JT-16-B provides better common mode rejection than transformerless designs, important in electrically noisy environments. It handles common mode voltages as high as $\pm 300V$ peak. Transformerless designs are usually limited to maximum voltages equal to their power supply voltages, typically $\pm 15V$ to $\pm 18V$.

The 990 Discrete Class-A Op-Amp is faster, quieter, more powerful and better sounding than the typical monolithic op-amps found in other equipment. Each individual (discrete) transistor, resistor, diode, capacitor and inductor of the 990 has been carefully chosen for its task. This provides a level of performance that is not possible in a monolithic op-amp where all components are fabricated on the same tiny chip of silicon. The

990 can drive long cables and loads as low as 75 Ω , something monolithic op-amps cannot do. See the 990 data package for further information.

Elimination of All Coupling Capacitors from the Signal Path results in less degradation of the audio signal. Two superior techniques are used to accomplish this:

1. *Input bias current compensation* circuitry nulls out the small DC currents (thus voltages) that flow from the inputs of the 990 (or any op-amp), voltages that could cause noise when operating the gain controls. This circuitry also reduces the DC offset voltage at the output of the 990. Most other mic preamps use coupling capacitors to block the input bias currents, resulting in signal degradation.

2. *DC servo* circuitry nulls out the DC offset voltage at the output of the 990, eliminating the need for a traditional output coupling capacitor to block that voltage. The signal degradation caused by that capacitor is also eliminated. See the schematic on page 2 for details.

Important Details

1% 100ppm Metal Film Resistors are used to provide greater initial accuracy, better long term stability, and higher stability at extremes of temperature.

Electrolytic Capacitors with a 105°C Temperature rating are used instead of the more common 85°C rated parts. This higher temperature capability means that they will last much longer than the lower rated parts. They

will also have better, more linear performance over a wider temperature range. Electrolytic capacitors are more failure prone than most other components. Sometimes they allow small amounts of DC current to pass through (leakage current), causing pots and switches to be noisy when operated. (NOTE: in the MPC-3000 there are no capacitors in the signal path, so this problem cannot exist). Other electrolytic capacitors

may short-circuit, or lose most of their capacitance. Whatever the failure mode, you have a problem, even in equipment that never approaches an operating temperature of 85°C. But *not* with the MPC-3000!

Fully Sealed 25-turn Cermet Trim Pots provide long, trouble-free life. Calibrations are more accurate and easier to achieve.

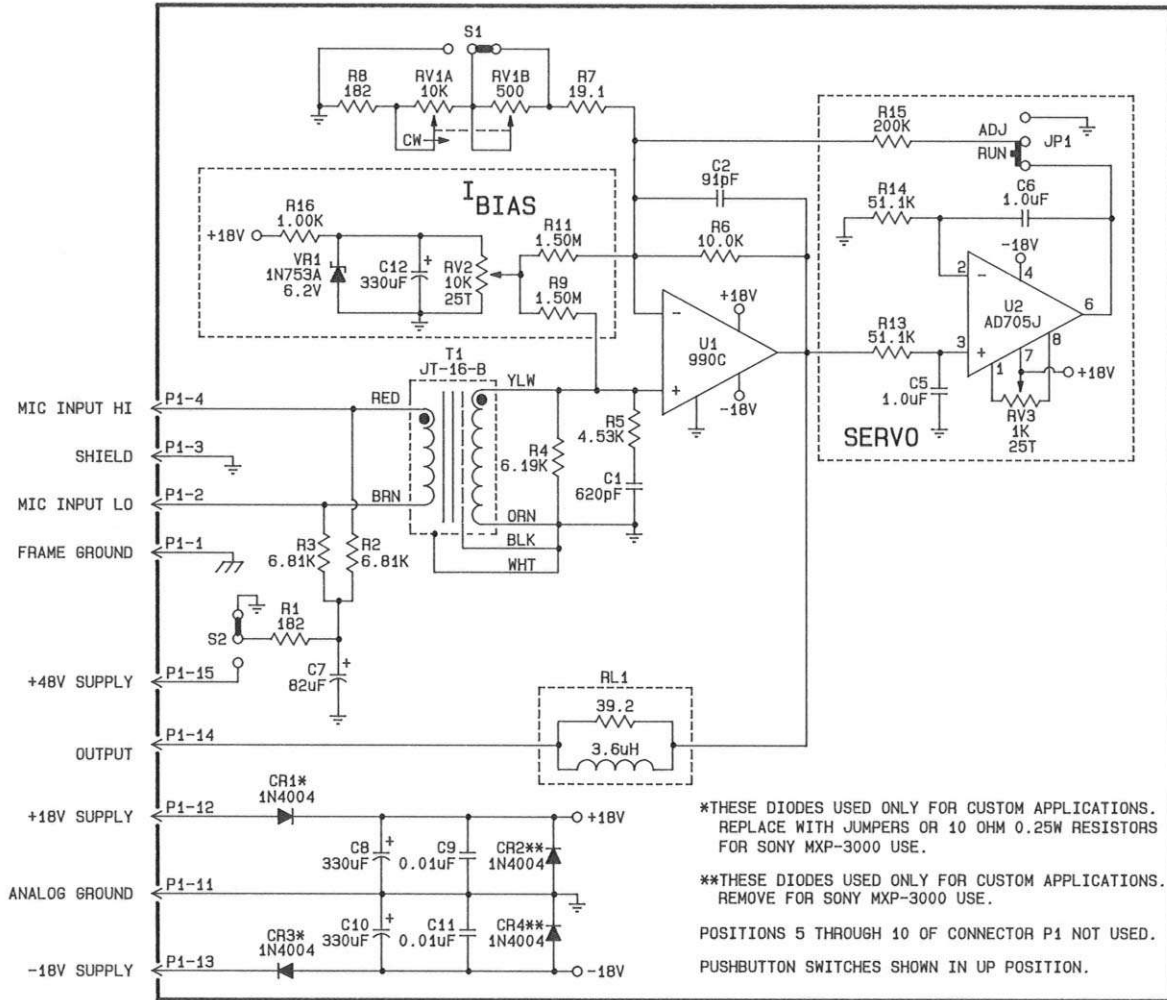

CONDENSED SPECIFICATIONS (0dBu = 0.775V)

E.I.N., 20-20kHz unweighted	150Ω source:	-129 dBu
	0Ω source:	-132 dBu
Maximum input level	≥20Hz:	+9 dBu
Maximum output level at 990 output	75Ω load:	+21 dBu
CMRR	100Hz:	100 dB
	10kHz:	80 dB
Deviation from linear phase	20Hz-120kHz:	<2 deg
THD:		
60dB gain, 10kΩ load, +21dBu output	10kHz:	0.005 %
	1kHz:	0.004 %
40dB gain, 600Ω load, +21dBu output	10kHz:	0.003 %
	1kHz:	0.003 %
40dB gain, 75Ω load, +21dBu output	10kHz:	0.030 %
	1kHz:	0.005 %
DC offset		<100 μV